



Unviersty of Anbar

Anbar Journal Of Engineering Science©

journal homepage: [http:// www.uoanbar.edu.iq/Evaluate/](http://www.uoanbar.edu.iq/Evaluate/)



Numerical Investigations of Bond-Slip Performance in Pull-Out High Strength Concrete Specimens Subjected to Elevated Temperature

Akram S. Mahmoud ^{a*}, Shamil K. Ahmed ^b

^a Department of Civil Engineering, College of Engineering, University of Anbar, Iraq

^b Department of Maintenance, University Headquarter, University of Anbar

PAPER INFO

Paper history:

Received 12/01 /2021

Revised 15/02/ 2021

Accepted 28 /02/2021

Keywords:

Bond-slip, pull-out test, Finite element, High strength concrete, and Elevated temperature.

ABSTRACT

The concrete members several blessings over steel beam, like high resistance to prominent temperature, higher resistance to fatigue and buckling, high resistance to thermal shock, fire resistance, robust resistance against, and explosion. However there are some disadvantages as a result of exploitation totally different materials to product it. The most downside of structural concrete member is its deprived the strength to tensile stresses.

The bond mechanism between steel bars and concrete is thought to be influenced by multiple parameters, like the strength of the encompassing media, the prevalence of cacophonous cracks within the concrete and therefore the yield stress of the reinforcement. However, properties of concrete mass has significantly effect when it was subjected to elevated temperature.

The objective of this paper presents the results that allocating with the bond behavior of the reinforcement of steel bar systems below static pull-out loading tests subjected to elevated temperatures. This numerical technique relies on relative slip and therefore the stress of bond distributions done the embedded length and size of the bar within the concrete cylinder specimens. The obtained results square measure given and commented with the elemental characteristics of ferroconcrete members. The comparison showed smart agreement with experimental results.

© 2014 Published by Anbar University Press. All rights reserved.

1. Introduction

In solid concrete areas, any place the strains of steel shift from the strains of concrete, a relative slip movement between the concrete and reinforcing steel has occurred. Along these lines, the bond normal for bars is regularly depicted due to the connection along stress of bond and subsequently the relative slip (slippage displacement) of reinforcing bar surfaces. Additionally, the relationship of stress of bond and slip is likewise pondered as a depiction of global conduct of concrete and steel bar at the interface of bar and concrete [1,2]. The mechanism of bond system within interface concrete and bar of steel reinforcement permits the diffusion of tangential supporting force to encompass concrete in a sound concrete structure. For fire environments, there are no just steel and concrete properties were

profoundly influenced using the raised temperature yet additionally of connection concerning them is affected. Subsequently, the performance of bond at high temperature, also the residuals stress of bond ought to be explored [3-5].

From the available literatures the bond strength has been experimentally studied by many researchers but a few papers deal with numerical analysis for bonding of high strength concrete specimens with a steel bar subjected to pull-out take an explore.

This paper deals with the numerical model was enforced by ANSYS, to investigate this case with elevated temperatures. Where the temperatures (150, 250, 400, and 500 °C) are studied to show the be-

* Corresponding author. : Akram S. Mahmoud : dr.akramsh1@uoanbar.edu.iq ; +964 7901582965

havior between slip-bond stress compared with available experimental data.

2. MECHANISM OF BOND AT ELEVATED TEMPERATURE:

The bond stress among concrete and steel at surrounding heat comprises types of three common components: adhesion, mechanical interlock, mechanism of friction. For a plain reinforcing (smooth) bars, the bond depends: fundamentally within the substance, union adhesion of composite steel and concrete surfaces, and when slip of grinding. While the deformed reinforcing bars (it have deferment around the bar surface), the mechanism of the interlock for the bar's spines installed within concrete mass is the key system to oversee the stress of bond [3]. At elevated temperatures, similar security instruments work, be that as it may; compressive quality and the rigidity of concrete are both decreased due to a elevated temperatures. Thusly, the bond force quality can be required to decrease in light of role fact that the temperature will increment. With worry to their decreasing of the stress. Morley and Royles [6] had demonstrated the rate of security decrease is more noteworthy than the comparing decrease in compressive and elasticity as appeared in Fig.1.

In other case, to the decrease in the properties of material, stresses from thermal because of slips due to thermal influence the bond execution at high temperatures. At a point when the bond is thought of, there are a three displacements due to thermal present (total concrete, total steel, steel - concrete)performance, which source an expansion in thermal stresses and a short time later additional splitting and collapse of concrete moreover the locale of solid interface of steel. This marvel escalates the decrease in concrete bond, as of now brought about by the abatement of solid quality at upraised or higher temperatures.

In term of the concrete stresses (compression and tension), the issued curve introduced in Fig(1) illustrates a fast drip in a quality after third hundred cellules is kept, mirroring the progressions occurring inside the solid because of loss of dampness and warm development (shrinkage of concrete glue and extension of the total). Another attributes of the bend is the decrease of the quality at temperatures around 100-150 °C. Morley and Royles [6] ascribed this decrease of solidarity to the total utilized in the

test which can cause variety in the concrete quality at elevated temperature.

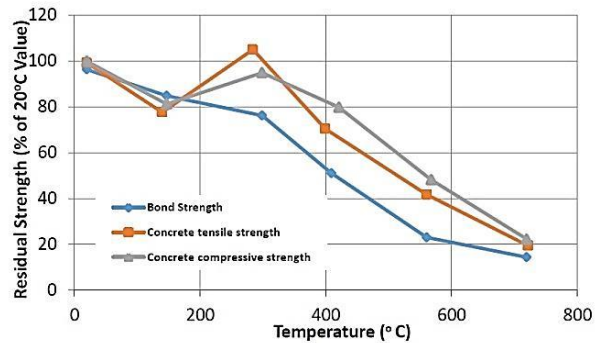

Figure 1. Comparison between bond strength reduction and concrete strength[6]

3. THERMAL STRESS ANALAYSIS :

The preminent components related to simulated numerical analysis of thermal stress activated using way of temperature's gradient inside a supported concrete mass is to be explored on this paper. Their utilization at excessive temperatures makes stresses due to elevated temperatures. Conveyance of temperatures from solid-thermal analysis is required inside the coupled environments investigation. Eventually to analyze heat mass transfer and its influence in determination of thermal stresses. In this manner, anticipated to require up a high temperature conductivity inconvenience the work of limited detail way to deal with acknowledge temperature circulation realities of a solid bar at over the top temperatures. the thought for warm examination in ANSYS [7-9] could be a warmth balance condition no inheritable from the statute of protection of intensity.

$$k \frac{\partial^2 T}{\partial x^2} + k \frac{\partial^2 T}{\partial y^2} + \dot{q} = \rho c \frac{\partial T}{\partial t} \dots\dots\dots (1)$$

Where:

c: Coefficient of heat specific (Joule/(kilogram.°C)).

K:Coefficient of thermal conductivity (W/(m.°C)).

ρ: Density (kilogram /m³).

q̇:Rate of heat generation (Joule /(m³.s)).

Accepting up to desire no heat mass transfer degree founds into the harden concrete, an experssion (q̇) execute can be canceled. Best possible part of answer delivered with the assistance of ANSYS results of nodal temperatures, at that point at that point

utilizes the nodal temperatures in conformity with reap lously fervent quantities. After that, the spirited stresses, caused through mechanical constraints nevertheless hot strains ensuing on the far side the previous analysis, hold been calculated.

4. GEOMETRY DETIALS OF TEST SPECIMEN:

Eight specimens of Al-Dulami [10] are chosen for the finite element analysis as shown in Figure (2). The Selected Pull-out take a look at specimens ar made up of high strength concrete, wherever divided in 2 teams, four specimens for every cluster. Group (A) deals with pull-out test of Ø20mm deformed bars with concrete cylinder 150x300mm, while group (B) deals with pull-out test of Ø12mm deformed bars within concrete cylinder 100x200mm.

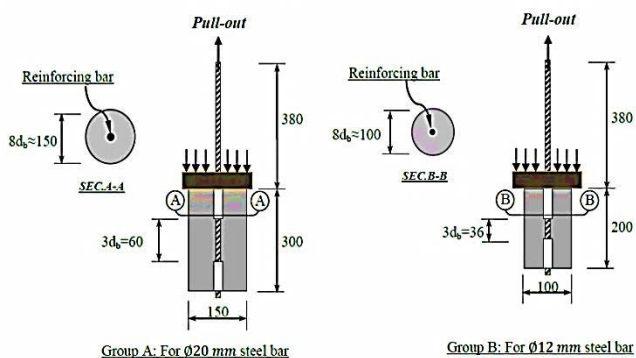

Figure 2. Pull-out specimen test Layout

5. FINITE ELEMENT MODEL:

Element Types

The rigid brick component, SOLID65, was once utilized in accordance with mannequin the concrete of ANSYS program. The consolidated issue has eight nodes with ternary tiers concerning ease at each node, translations into the nodal x, y, then z directions. The factor is capable relating to plastic deformation, nonetheless cracking among three orthogonal directions. The two-noded LINK8 bar (truss) stability part wont to be aged in accordance with mannequin the metal reinforcement. At every node, the amount of consolation ar identical in accordance with those for the SOLID65. The factor is additionally winning relating to plastic deformation. purpose to purpose contact component (CONTAC 52) was wont to model bond-slip of reinforcement bar with-

in the gift study. The component joins 2 surfaces that will maintain or break physical contact and should slide relative to every alternative. Also, it's capable of supporting solely compression within the direction traditional to the interface between the 2 surfaces and Coulomb shear friction within the tangential direction. The three-D point-to-point contact component has 3 degrees of freedom at every node within the component arrangement. The orientation of the interface is outlined by the node locations.

A thermal model of the adaptation became wont to estimate the temperature profile inside the concrete mass; the model of structural version analyze the layout of temperatures for estimating the stresses at the simulated elements. A Three dimensional 8-nodes with tetrahedral solid shape element involving a thermal gradient of opportunity is picked for thermal physical wonder inconvenience. Then, the thermal elastic strain elements distributions are evaluated by suggesting that of shift the thermal element (Solid 70 element) to equiponderant structural element (Solid 65 element), the details in Fig.(3) that is modeled for three-dimensional modeling for stable systems [7,8].

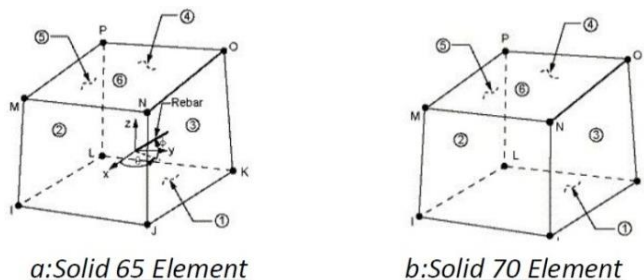

Figure 3. Structural and thermal used elements

primarily in view of a equation one has attaching thought of deliberation conditions of transient obstacles, the thermal stable for the auxiliary at structural studied nodes for a time step (t+Δt) is illustrated using equation (2):

$$\{F\} = [K]\{T(t + \Delta t)\} + [C]\{\dot{T}(t + \Delta t)\} \dots\dots(2)$$

[C]: means that matrix of heat capacity involving the coefficient of specific heat (c).

{Ṫ}: Nodal temperature for time gradient vector {(∂T/∂t)}.

[K]: Matrix of conductance involving coefficient of physical conductivity (k) and coefficient of thermal exchange convection (h).

$\{F\}$: Vector of thermal nodal-forces at each studied nodes .

An established Euler arrange are often executed. A tendency has been expected the next approximation by a primary time-by-product of the field of temperature [11]:

$$\{T(t + \Delta t)\} = \{T(t)\} + (1 - \theta)\Delta t\{\dot{T}(t)\} + \theta\Delta t\{\dot{T}(t + \Delta t)\} \quad \dots\dots(3)$$

Being $\theta = [0,1]$ and ΔT the time step, we can re-write after some modifications;

$$\left(\frac{1}{\theta\Delta t}[C] + [K]\right)\{T(t + \Delta t)\} = \{F\} + [C]\left(\frac{1}{\theta\Delta t}\{T(t)\} + \frac{1-\theta}{\theta}\{\dot{T}(t)\}\right) \quad \dots\dots(4)$$

A transient thermal analysis follows primarily a similar procedures as a steady-state thermal analysis. The most distinction is that almost all applied hundreds in a very transient analysis ar functions of your time. To specify time-dependent hundreds, one will divide the load-versus-time curve into load steps.

A solid pull out take a look at model illustrate in Fig.(2) is discredited within a three-dimensional finite element simulating model as illustrating in Fig.(4). There have the mechanical properties of used elements are given in Table one.

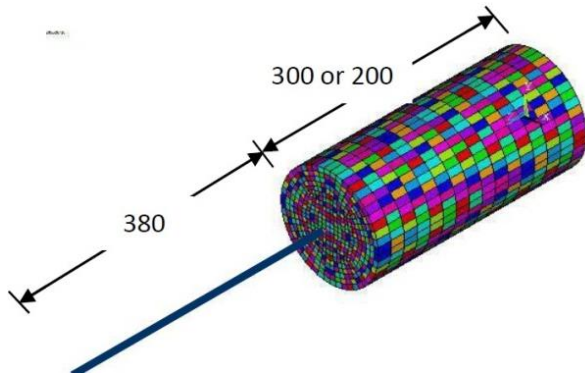

Figure 4. Finite element mesh of pull-out specimens created using ANSYS 12.0 package

6. Material Properties

For Concrete body, SOLID65 components square measure capable of predicting the nonlinear behavior of concrete materials mistreatment smudged crack approach Willam a nd Warnke [12]. The smudged crack approach has been adopted wide

within the last decades. Concrete may be a quasi-brittle material and has terribly completely different behaviors in compression and tension. The strain-strain relation for concrete in compression was painted by multilinear elastic model as shown in Fig.(5). supported the compressive strength of concrete, the stress-strain relationship was obtained mistreatment the equation(5) [12]:

Table 1. Thermal and structural used element properties contac52 element

Element	Thermal	Structural
Type	SOLID 70	SOLID 65
Number of Nodes	8	8
Number of DOF per Node	1	3
Nature	Temperature	Displacements: Ux, Uy and Uz

$$f = \frac{E_c \varepsilon}{1 + \left(\frac{\varepsilon}{\varepsilon_o}\right)^2} \quad \dots\dots(5)$$

Where,

f : stress of concrete at any step of strain ε , (MPa).

ε : strain at any step stress f (mm/mm).

ε_o : strain at the ultimate compressive strength f'_c , (where, $\varepsilon_o = 2f'_c/E_c$)

E_c : Concrete elastic modulus (where, $E_c = 4700\sqrt{f'_c}$, in MPa) [13]

For steel reinforcement a linear isotropous hardening with (Von- Mises) yield criterion model is utilized to stipulate the material properties of steel bar. The tensile yield and ultimate stress of steel based on the test data as shown in table (2) is used in the present analysis .

Bond- Slip Model: The interface part (CONTACT 52) is capable of supporting solely compressive forces within the direction traditional to the interface surface and shear (Coulomb friction) within the tangential direction. The interface part (CONTACT 52) could have one among 3 conditions:closed and stuck, closed and slippy, or open. The force-deflection relationships for the interface part (CONTACT 52) are often separated into traditional and tangential (sliding) directions as shown in Fig.(6).

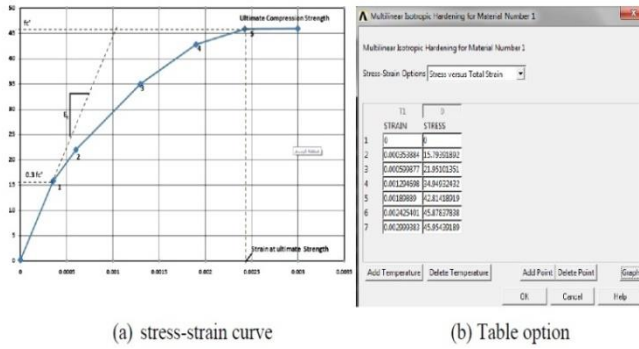

Figure 5. The adopted (Stress-Strain) curve of concrete

Table 2. Properties of steel reinforcement [10]

Bar Diameter (mm)	Area (mm ²)	f _y (MPa)	f _u (MPa)
12	113	537	652
20	314	556	705

The part (CONTACT 52) is outlined by 2 stiffnesses: traditional stiffness (k_n) and tangential stiffness (k_s). the traditional stiffness (k_n) is calculated from the equation (6). [14-16]

$$k_n = \frac{d}{0.7} \left[\pi \cdot E_s \cdot K_f^3 \left(\frac{f'_c}{27.4} \right)^{6\frac{1}{4}} \right] \dots (6)$$

Where:

E_s: Elastic Modulus for steel bar.

K_f: is the foundation modulus, depending on the tensile stress in the reinforcement as explained in equation (7):

$$K_f = 820 - 1.17 f_s \dots (7)$$

Where, f_s is the tensile stress within the reinforcement (MPa).

The tangential (sticking) stiffness (k_s) is found by multiplying the friction by traditional stiffness. The input file for the concrete, steel reinforcement,

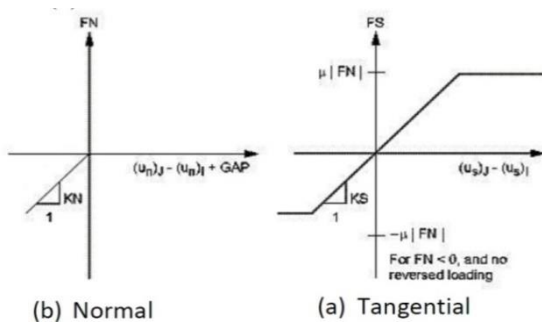

Figure 6. Interface force-deflection relationship by ANSYS

and interface part are summarized in Table (3).

7. Finite Element Modeling

The specimen could be a concrete cylinder of 150mm diameter, and 300mm length, with single homocentric plain bar. Contact parts (interface elements) square measure or else used at the interface between the concrete and also the steel bar. to get smart results from the concrete component (Solid 65) is organized in an oblong mesh i.e., the mesh is set-up specified sq. or rectangular parts square measure created. The meshing of reinforcing bar has corresponded to the meshing of concrete volume. The boundary conditions for the geometric model square measure applied by fixing the nodes at the highest surface of cylinder in 3 directions except the nodes adjacent to the steel bar and also the nodes of boundless length mounted in 2 directions (x and y). The finite component model of the cylinder specimen is shown in Fig. (7) .

8. THERMAL AND STRUCTURAL BOUNDARY CONDITIONS

The temperatures of (150, 250,400,or 500°C) were applied to the bottom of the concrete specimens, and twenty ° C was applied to the core by convection with a movie constant of fifty W/m2/°C. The concrete initial temperature is ready to 20°C. The temperature is obtained via Galerkin finite component technique as enforced by ANSYS code package [7,8].

A: THERMAL ANALYSIS

The supporting conditions are enforced, therefore, the drawback is resolved an exploitation frontal convergent thinker in ANSYS software. The results of temperature distribution of elements are obtained within the general postprocessor stage. These results therefore evaluated and premeditated in Figs.(8,10) for illustrating the profiles of temperature and Figs.(9,11) for illustrating the thermal flux diagrams.

B: STRUCTURAL ANALYSIS

The relationships between the temperature choice and in this manner the associated mechanical strain-thermal strain- might be conveyed as :

$$\epsilon_{thermal} = \alpha \cdot \Delta T \dots (8)$$

Where:

($\epsilon_{\text{thermal}}$) is that the deformation due to thermal distortions, (α) is the thermal gradient growth constant ($^{\circ}\text{C}^{-1}$), and (ΔT) is the change in temperatures within two time steps ($^{\circ}\text{C}$).

The recreation of the thermal exchange and conjointly the related thermal stresses will be completed by utilizing the transient thermal stress investigation, that is out there among the limited half mechanical code ANSYS .

Thermal-stress simulations are dealt with during a supposed coupled-discipline investigation, that thinks about the collaboration between thermal enlargement/contraction and mechanical stresses. On account of the very actuality inside the blessing case of stress won't have a direction on temperature, the solutions are tended to during an a way coupling

situation best restricted with the assistance of the circuitous methodology, inside which nodal temperatures from a (period brief) warm investigation ar applied at a top to bottom time inside the ulterior (customary state) stress examination. the other from warm to basic examination is easily accomplished in ansys in light of the fact that the detail switch is programmed. A thermal solid70 elements to basic reaches the solid 65 elements kind. The temperatures obtained from the previous analysis are literally enforced as a load to determine thermal stresses and displacements and totally different parts. then the behaviour of bond slip can issued with the restrained enlarged temperature.

Table 3. Materials properties of the specimens

Material Type	Parameter	Values for	
		Case (Ø12 mm)	Case (Ø20 mm)
Concrete	Compressive strength f'_c (MPa)	48	45.2
	Tensile strength f_t (MPa)	3.84	3.71
	Young Modulus (MPa)	32565	31600
	Poisson's Ratio (ν) (assumed)		0.2
	Density (N/m ³)		24000
	Thermal Conductivity (k) (W/m.oC)		1.2
	Specific Heat Capacity (c) (J/kg. oC)		1000
	Thermal Expansion Coefficient (α) (1/ oC)		1.2x10-5
	Actual diameter (mm)	11.79	19.62
	Bonded length (mm)	36	60
Reinforcing Steel	Yield Strength (MPa)	537	556
	Young Modulus (MPa)		200000
	Poisson's Ratio (ν) (assumed)		0.3
	Density (N/m ³)		78750
	Thermal Conductivity (k) (W/m.oC)		60
	Specific Heat Capacity (c) (J/kg. oC)		500
	Thermal Expansion Coefficient (α) (1/ oC)		1.08x10-5
Interface (Contact)	Coefficient of friction (μ) (assumed)		0.3

9. RESULTS AND DISCUSSION:

The analyses ar dispensed to analyze the behavior of bond-slip behaviour in concrete specimens subjected to elevated temperatures. ANSYS V.12.0 computer code is employed for a finite component modeling. Verification is finished so as to examine the validity and accuracy of those models. the power of the essential models to simulate the behavior of this sort of members ar incontestable through the analysis of the

tested specimens. the expected results mistreatment FEM model is compared with the experimental results through the load-slip plots. Finite component results are compared with offered experimental knowledge. The numerical results of the finite eminent analysis compared with the experimental results are illustrated in figures (12-15) for the load-slip behaviour relations.

The predicted final load compared with the experimental for all the tested specimens ar given in Ta-

ble(4). it's clearly seen from Table (4) and figures (12-15), that the expected results of the planned model utilized in finite component analysis mistreatment ANSYS V.11 computer code show an honest agreement with the experimental observation for load-slip relationships.

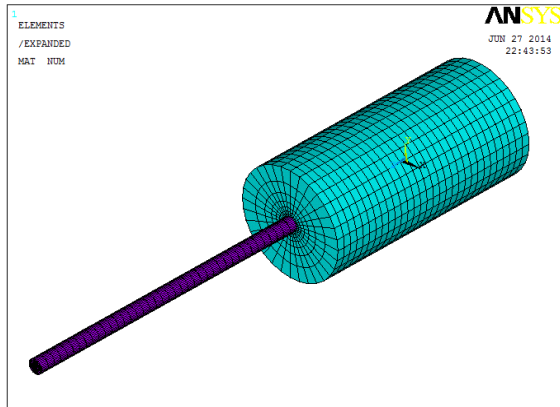

Figure 7. Applying the boundary conditions and applied force.

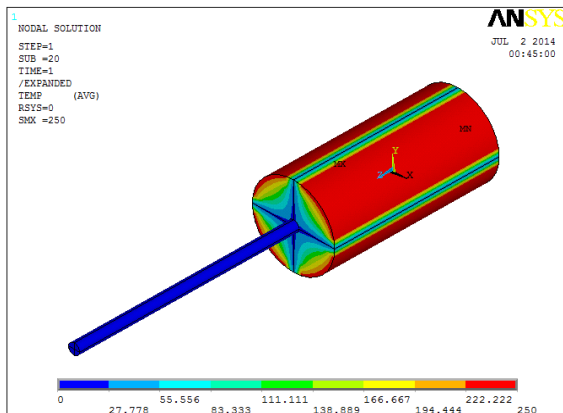

Figure 8. Temperature profile at (T = 250°C)

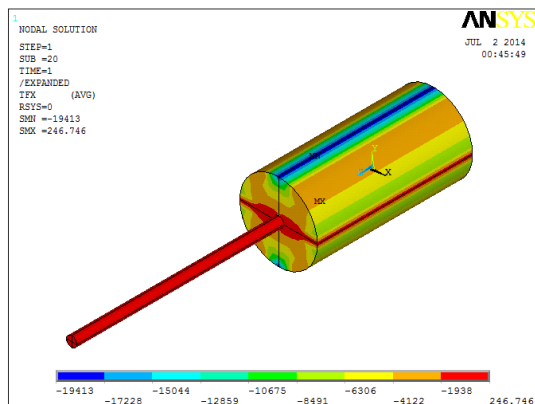

Figure 9. Thermal flux at (T = 250°C)

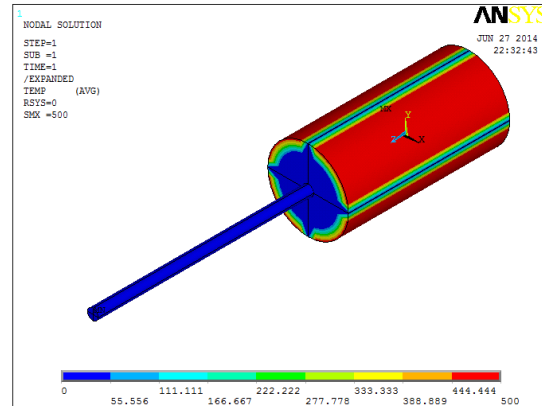

Figure 10. Temperature profile at (T = 500°C)

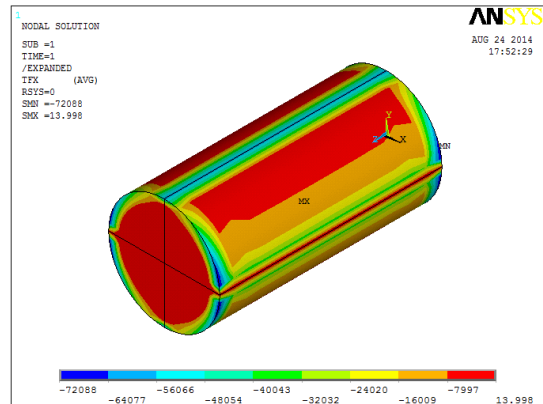

Figure 11. Thermal flux at (T = 500°C)

10. CONCLUSIONS

From this study, many conclusions can be derived as listed below:

1. The outcomes found in the trial which the bond-slip relationships identified with the mode of bar influenced the method of the disappointment of the structure, wasn't shown inside the considered numerical model. The general displacements of the contemplated models were comparable and modest when put close to the check results. Accordingly, a further investigation considering the all out strain layout in direction x-axis was directed to outline the impact of various bond-slip curves for tested specimens.
2. An elevated temperature (more than 250 °C) the temperature distribution still has a significant affect at the cover region, after reach the specified temperature. In other wise, when increase d the temperature the destitution of

temperatures have been rapidly affect. That will be need little time to effect on bond behavior.

3. The heat flex in to concrete structure was different configuration due to the higher temperature can be passed through concrete rapidly.

4. When using higher compressive strength, the bond of steel reinforcement had been increased due to increasing the confining and adhesive phenomena.

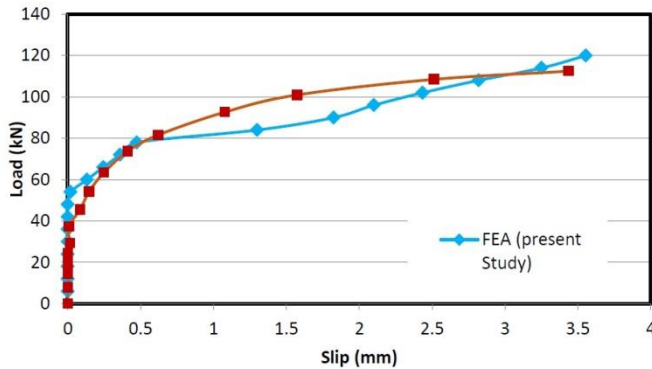

Figure 12. Experimental verse FEA of load-slip relationship at (T = 25°C, Room Temperature) for group (A)

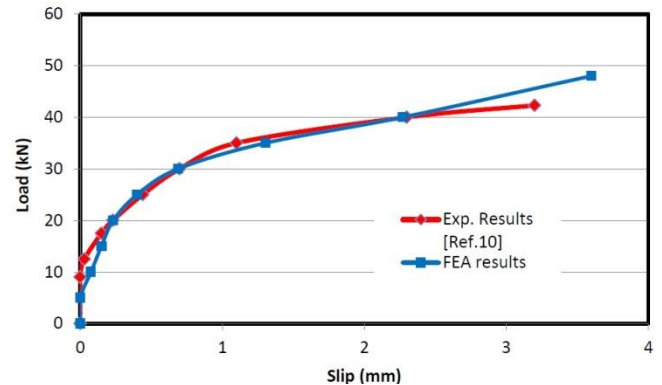

Figure 14. Experimental verse FEA of load-slip relationship at (T = 25°C, Room Temperature) for group(B)

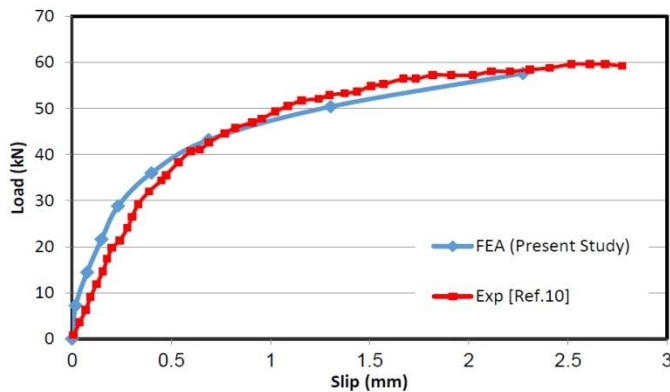

Figure 13. Experimental verse FEA of load-slip relationship at (T = 500°C) for group (A)

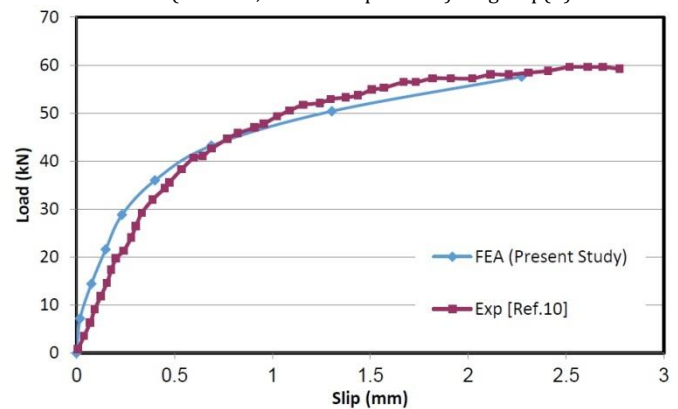

Figure 15. Experimental verse FEA of load-slip relationship at (T = 500°C) for group(B)

REFERENCES

- [1] Yankelevsky, D. Z. Analytical Model for Bond-slip Behaviour Under Monotonic Loading, Building and Environment, Vol. 20, No. 3, pp. 163-168, 1985.
- [2] FIB Bulletin No. 10. Bond of reinforcement in concrete: State-of-art-report. Fédération Internationale du Béton, 153, Stuttgart, Germany, 2000.
- [3] Grauers, K et al. "Anchorage and Shear in Concrete Structures Exposed to Fire –A Literature Review" Brandforsk – project M.53 Swedish National Testing and Research Institute, Report 1994:02, 1994.
- [4] Morley, P. D. and Royles, R. The Influence of High Temperature on the Bond in Reinforced Concrete Fire Safety Journal, November 1979, pp 243-255
- [5] Bazant, Z. P. and Kapla, M. F. Concrete at High Temperature –Material Properties and Mathematical Model Longman Group Limited, 1996.
- [6] Morley, P. D. and Royles, R. Further Responses of the Bond in Reinforced Concrete to High Temperature Magazine of Concrete Research, Vol 35, No.124,September 1983
- [7] ANSYS V.12 "ANSYS Theory Reference: Analysis tools", 001099, 9th ed. SAS IP, Inc.
- [8] ANSYS Thermal Analysis: Tutorial for Rev. 5.0, DN-T031:50, 6., 1992.

- [9] Dahmani, L., "Thermo mechanical response of LNG concrete tank to cryogenic temperatures", *Strength of Materials*, Vol. 43, No. 5, 2011, pp. 526-53.
- [10] Al-Dulaimi, W. K. H.(2011)"Effect of Elevated Temperature on Bond Strength in Different Types of Reinforced Concrete", M.Sc. Thesis, College of Engineering, Anabr university, Iraq.
- [11] Ngo, D. and Scordelis, A.C., "Finite Element Analysis of Reinforced-Concrete Beams". *Journal of the American Concrete Institute*, Vol. 65, No. 9, 1967, pp.757-766.
- [12] Willam,K., and Warnke, E., "Constitutive Model for the Triaxial Behavior of Concrete", *Proceedings, International Association for Bridge and Structural Engineering*, Vol.19, ISMES,pp.174, Bergamo, Italy, 1975.
- [13] ACI Committee 318M (2011) "Building Code Requirements for Structural Concrete." American Concrete Institute, Michigan, USA.
- [14] Fardis, M., and Buyukozturk, M., "Shear Stiffness of Concrete by Finite Elements"ASCE Proceedings, *Journal of Structure Division*, Vol. 106, No.St6, June 1980, PP.1311-1327.
- [15] Zayan H.S., Farhan J.A., Mahmoud A.S., AL-Somaydaii J.A. (2019) A Parametric Study and Design Equation of Reinforced Concrete Deep Beams Subjected to Elevated Temperature. In: Pradhan B. (eds) GCEC 2017. GCEC 2017. Lecture Notes in Civil Engineering, vol 9. Springer, Singapore. https://doi.org/10.1007/978-981-10-8016-6_15.
- [16] Salih, Z.T., and Mahmoud, A.S. (2019), "Numerical Analysis of Reinforced Concrete Columns Strengthened By Steel Tubes Under Sustained And Short Term Loadings", *International Journal of Computer Aided Engineering and Technology* (In press).